

Glider Instruments

Richard Lancaster

R.Lancaster@carrotworks.com

ASK-21 glider outlines Copyright 1983 Alexander Schleicher GmbH & Co.
All other content Copyright 2008 Richard Lancaster.

The latest version of this document can be downloaded from: www.carrotworks.com

[Atmospheric pressure and altitude]

1 Atmospheric pressure is caused by the weight of the column of air above a given location.

At sea level the overlying column of air exerts a force equivalent to 10 tonnes per square metre.

2 The higher the altitude, the shorter the overlying column of air and hence the lower the weight of that column.

3 Therefore:

“Atmospheric pressure decreases with altitude.”

At 18,000ft atmospheric pressure is approximately half that at sea level.

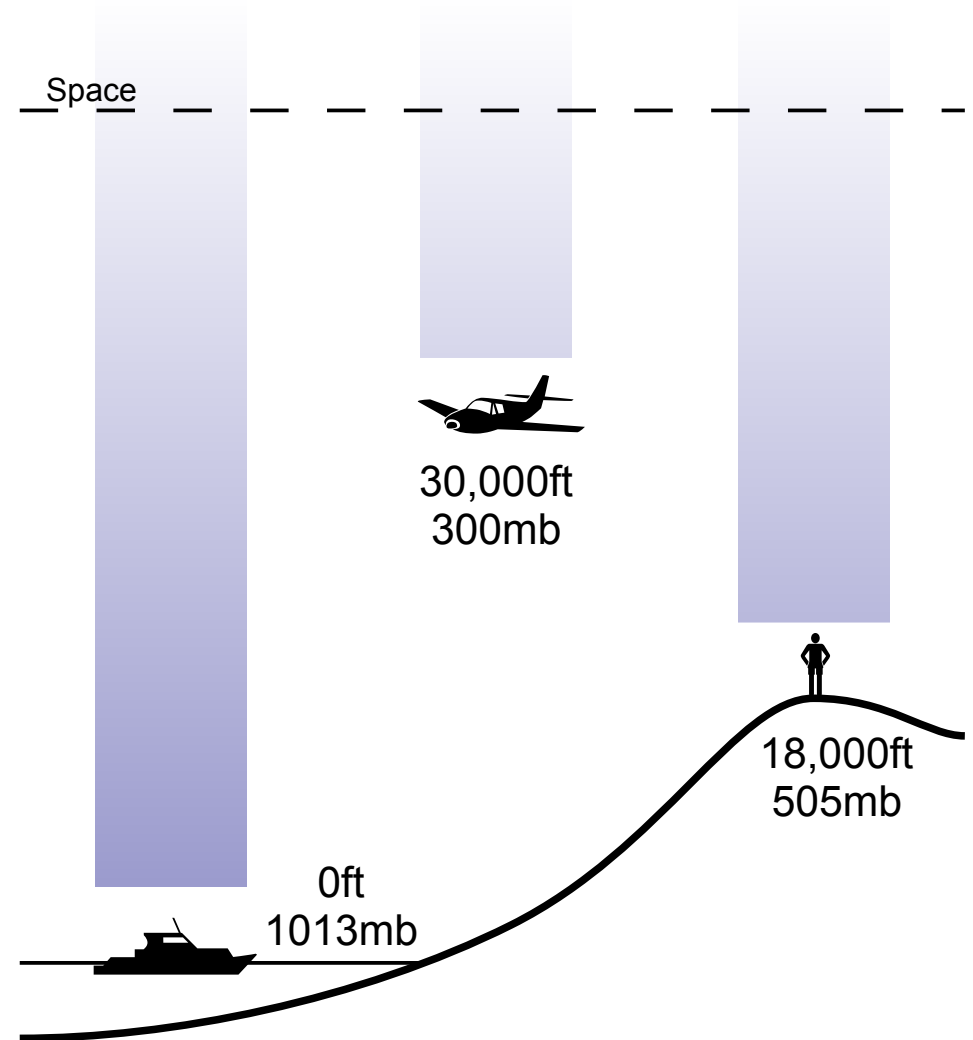

[The altimeter]

[Altimeter anatomy]

Aneroid capsule:

A sealed copper and beryllium alloy capsule from which the air has been removed.

The capsule is springy and designed to compress as the pressure around it increases and expand as it decreases.

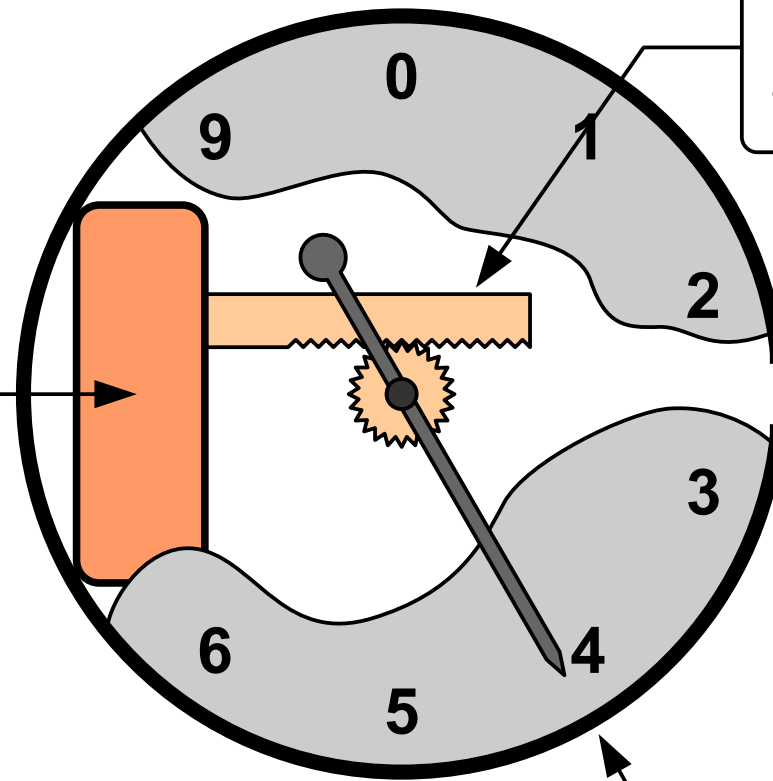

Linkages and gearing:

Connect the aneroid capsule to the display needle(s).

Enclosure:

Airtight except for the static pressure inlet. Has a glass front through which display needle(s) can be viewed.

[Altimeter operation]

1 The altimeter's static pressure inlet must be exposed to air that is at local atmospheric pressure.

2 The pressure of the air inside the altimeter's casing will therefore equalise to local atmospheric pressure via the static pressure inlet.

3 Atmospheric pressure decreases with altitude.

4 As atmospheric pressure decreases the aneroid capsule expands, moving the linkages and hence rotating the display needle(s).

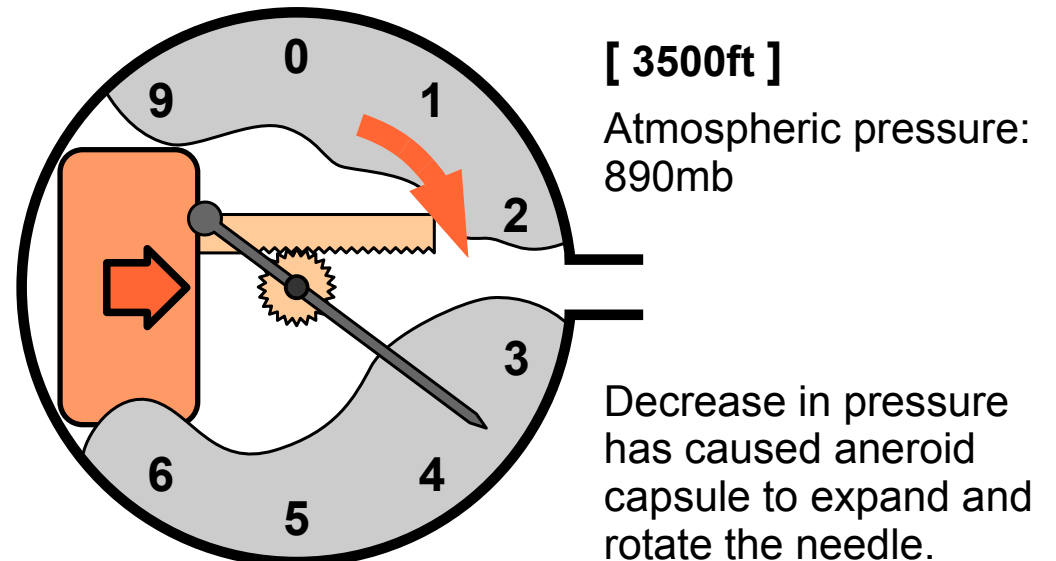
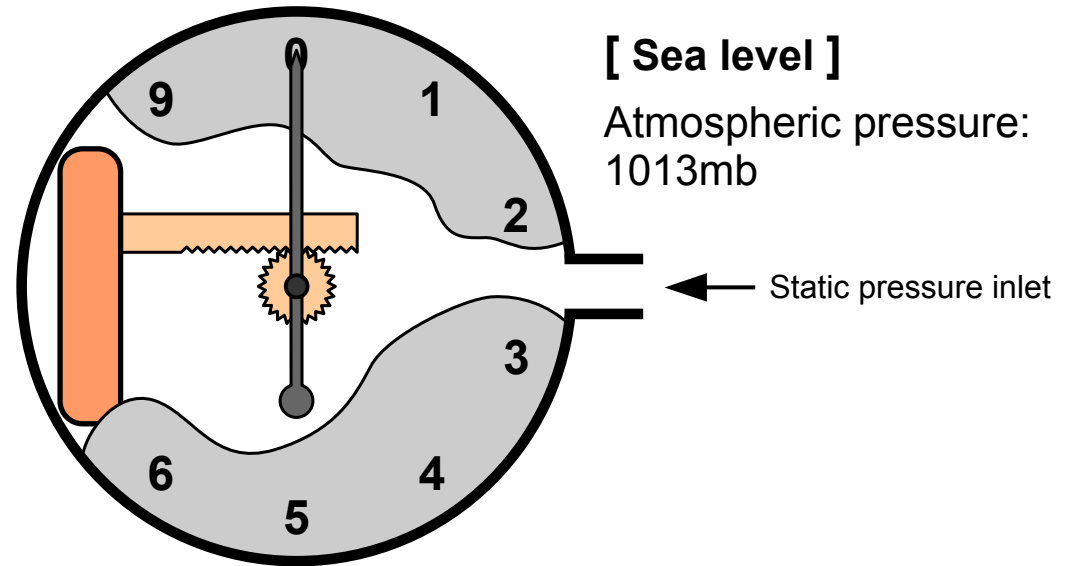

[Atmospheric pressure disturbances]

1 An aircraft moving through the atmosphere changes the pressure of the air surrounding it. This is how wings generate lift. Even the air inside the cockpit will not quite be at local atmospheric pressure.

2 This means that care must be taken when trying to expose the altimeter's static pressure inlet to air that is at local atmospheric pressure.

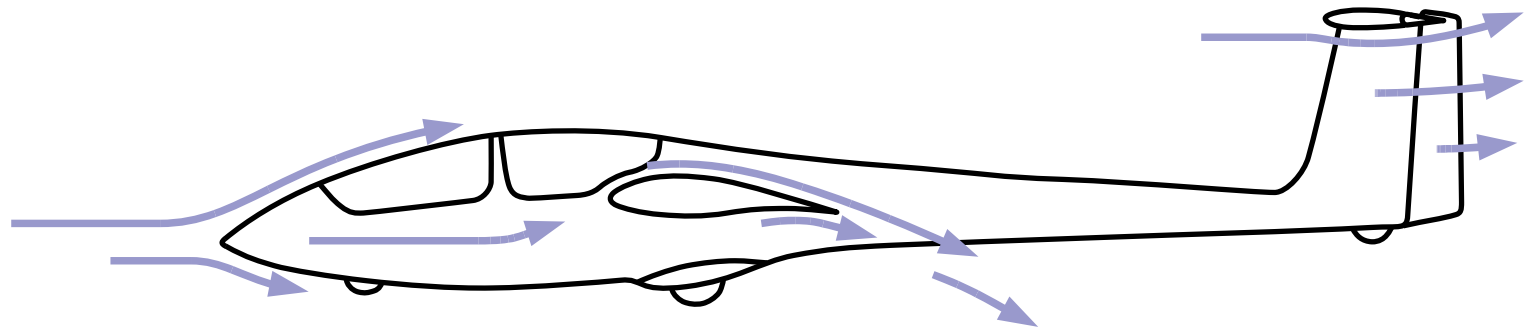

[Static vents and altimeter pipework]

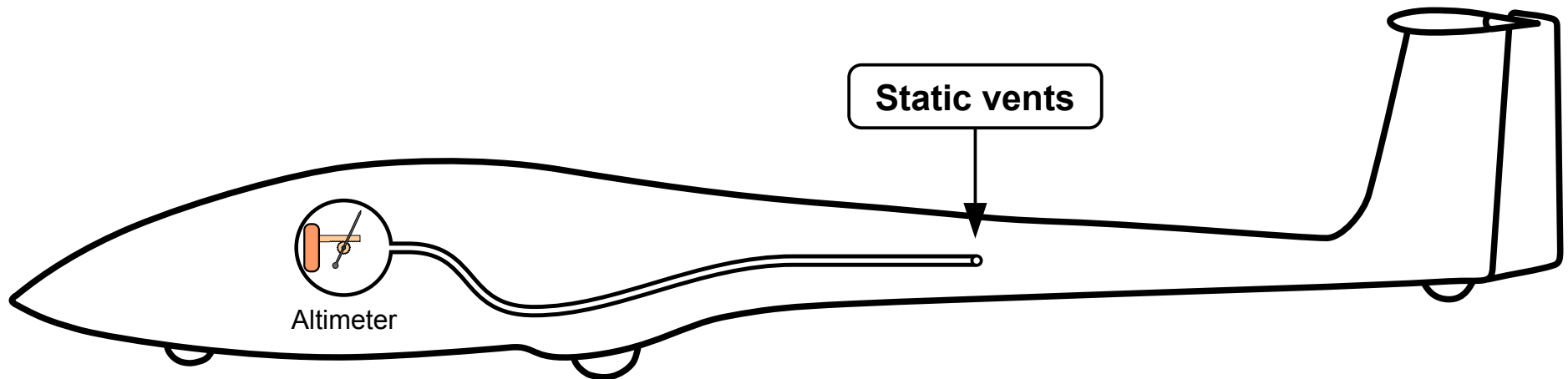

1 When designing a glider, the engineers will try to find a location on the fuselage where the passing airflow exerts a pressure on the aircraft's surface that is close to local atmospheric. They do this using a combination of their experience, calculations and test results. On a glider, such a point is often located about half way down the tail boom.

2 A pair of “**static vent holes**” are drilled into the fuselage at this location and connected to the altimeter's static pressure inlet via a flexible plastic tube. This allows the air in the altimeter's casing to equalise with local atmospheric.

[Barometric pressure subscale]

1 The adjustment knob on the front of an altimeter allows the pilot to dial in, on the **barometric pressure subscale**, the current atmospheric pressure at the altitude they wish to call 0ft. For example they might dial in the current pressure at sea level, or the current pressure at ground level on a particular airfield.

2 The knob adjusts the linkages within the altimeter, such that when the atmospheric pressure around the aircraft matches the setting on the subscale the altimeter will read 0ft.

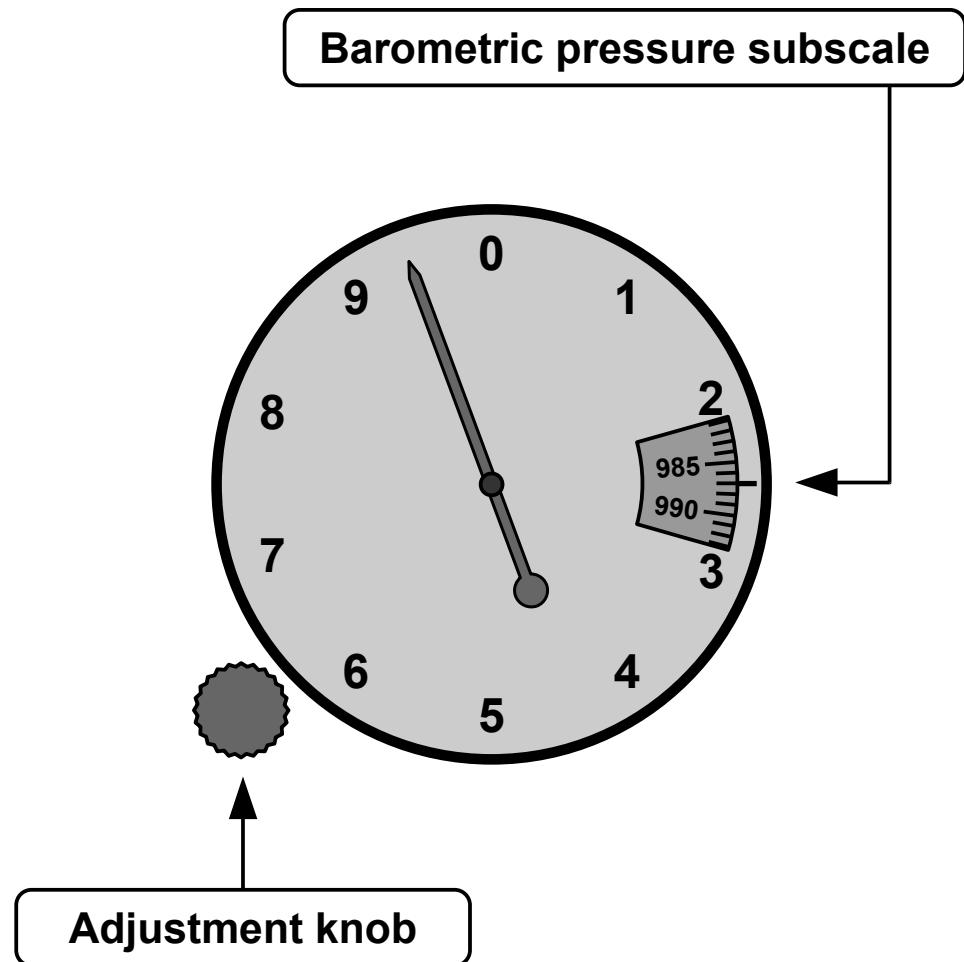

[Air Speed Indicator (ASI)]

[The Pitot tube]

Pitot tube:

A tube, often mounted in the glider's nose, the open end of which is exposed directly to the oncoming airflow.

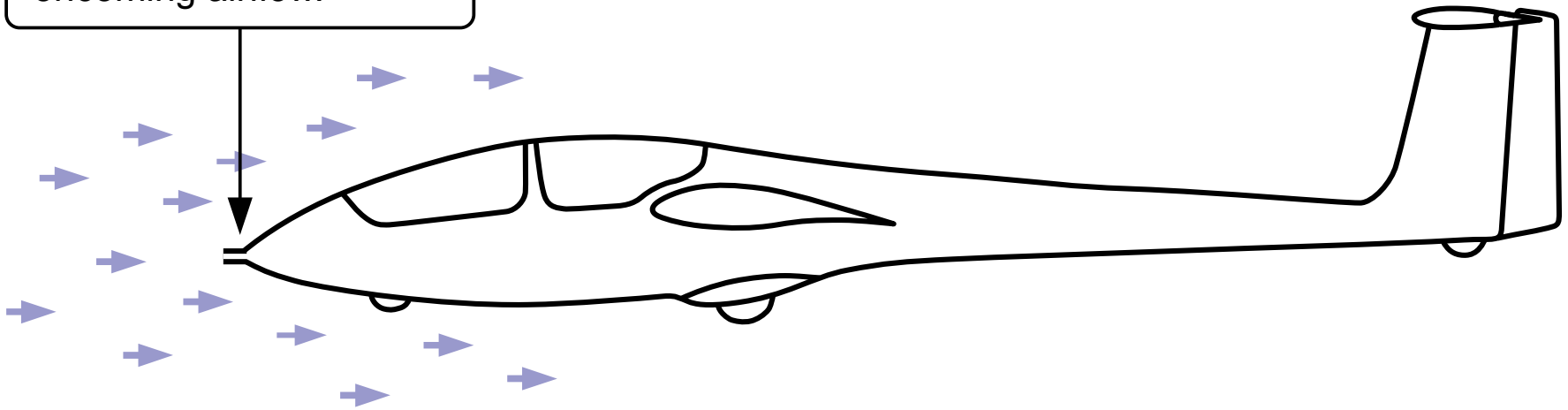

[Pitot tube characteristics]

1 When a glider is in flight, the oncoming air will try to flow into the open end of the Pitot tube.

2 Connecting a capsule to the back end of the Pitot tube will mean that the air flowing in has nowhere to go. The pressure in the capsule will therefore rise until it is high enough to prevent any further air from entering.

3 Increasing the airspeed of the glider will cause the force exerted by the oncoming air to rise. More air will therefore be able to push its way into the capsule and hence the pressure within the capsule will increase.

4 The pressure inside the capsule will therefore increase as airspeed increases.

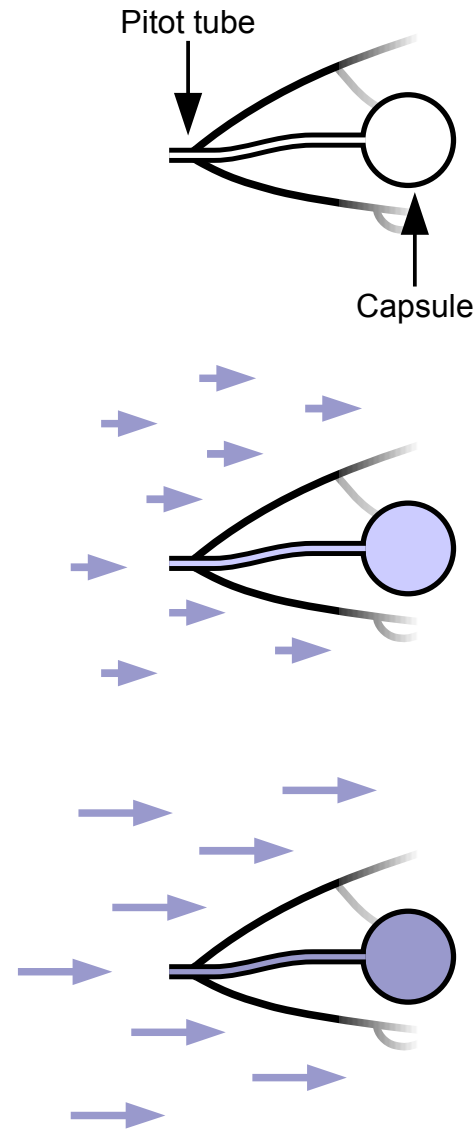

[Speed: 0kts]
No oncoming airflow.
Capsule pressure: 1013mb
E.g. sea level atmospheric

[Speed: 30kts]
Capsule pressure: 1015mb
Sea level atmospheric
+ 2mb due to oncoming airflow

[Speed: 60kts]
Capsule pressure: 1019mb
Sea level atmospheric
+ 6mb due to oncoming airflow

[ASI anatomy]

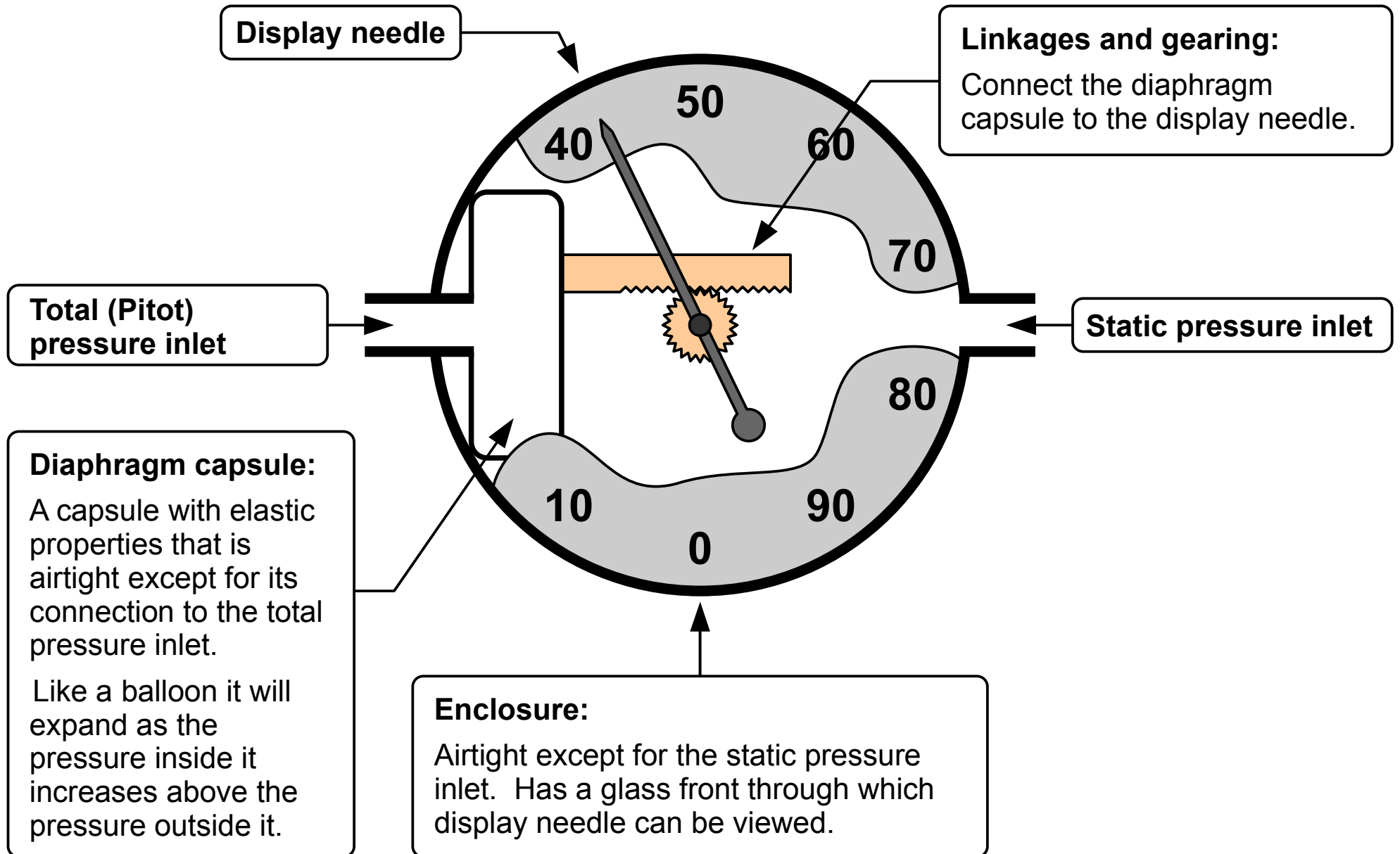

[ASI pipework]

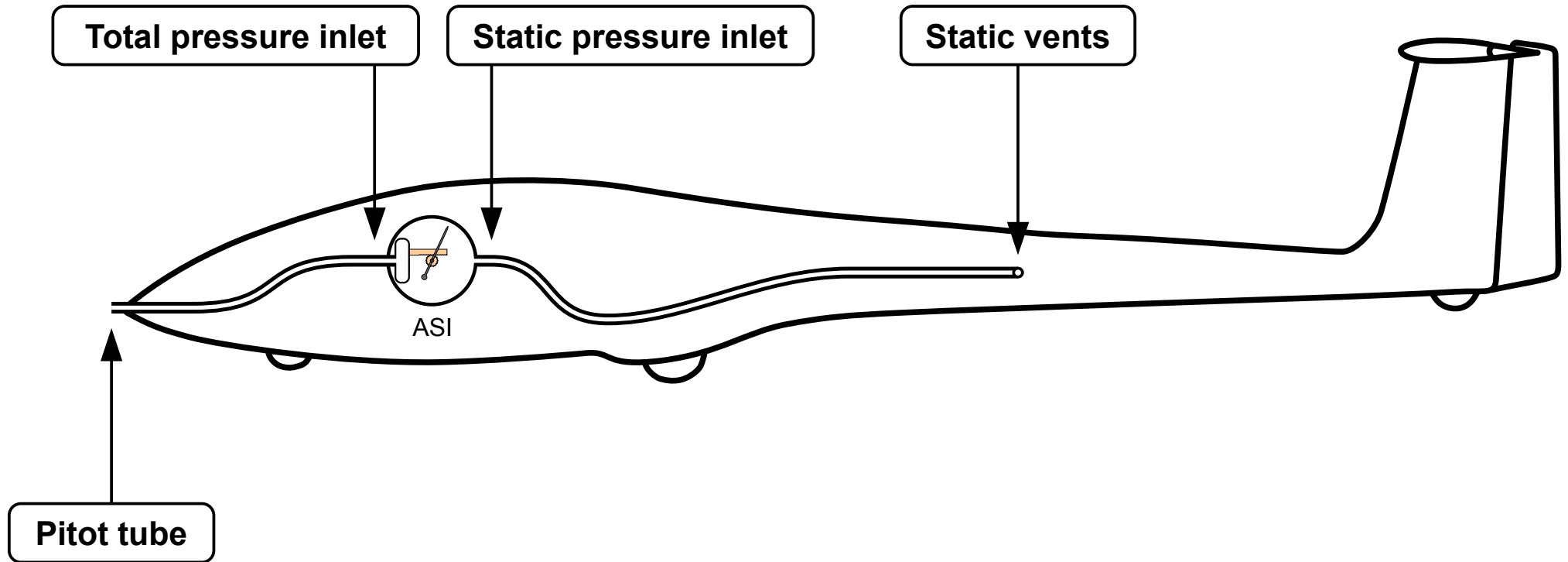

[ASI operation]

1 In a stationary aircraft, the air throughout the ASI will have equalised with local atmospheric pressure. The diaphragm capsule will therefore be collapsed like a deflated balloon and the needle will be displaying zero.

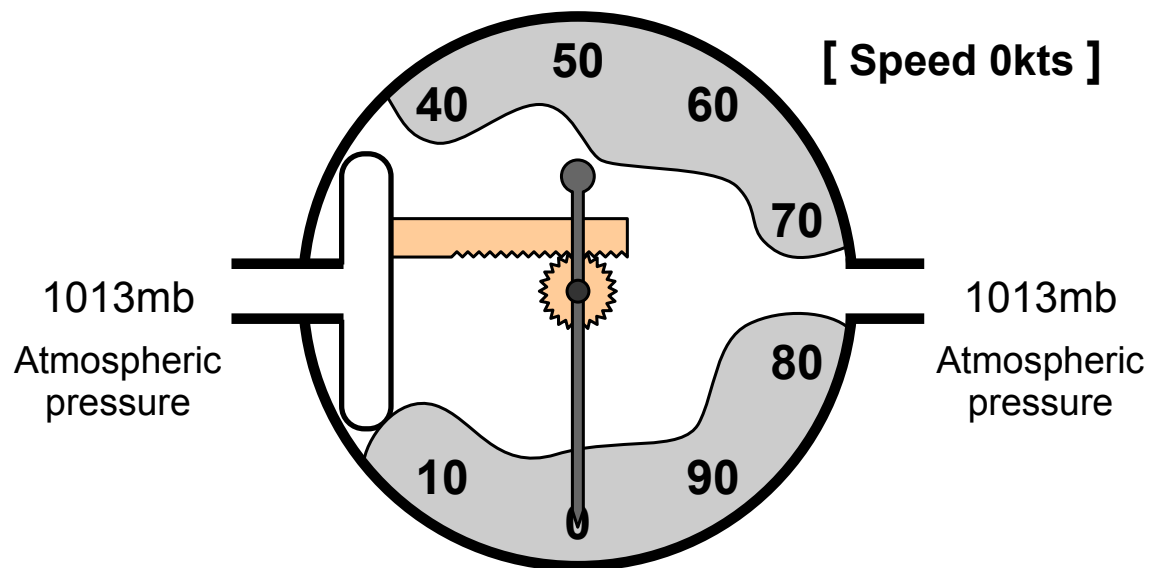

2 As airspeed increases, the pressure inside the diaphragm capsule will rise above local atmospheric due to the force exerted down the Pitot tube by the oncoming airflow. The capsule will therefore inflate like a balloon, moving the linkages and rotating the needle.

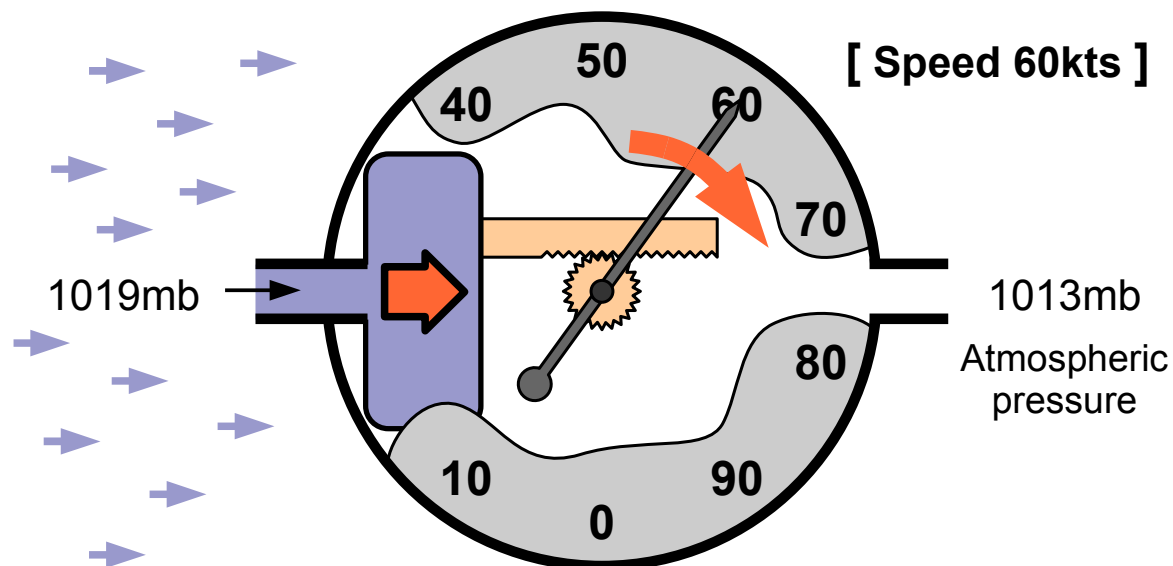

[The effect of altitude on the ASI]

1 Like pressure, air density also decreases with altitude.

2 The ASI's diaphragm capsule is calibrated to correctly display airspeed when the air that the aircraft is moving through is of average sea level density.

3 Above sea level, due to the lower air density, the build up of pressure in the diaphragm capsule will be lower than the ASI expects it to be. The ASI will therefore under read.

4 The higher the altitude above sea level the more the ASI will under read.

ASI of an aircraft flying at 60knots at sea level

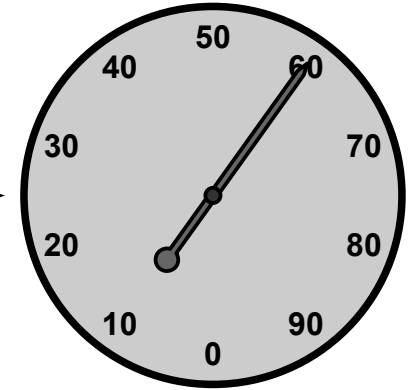

ASI of an aircraft flying at 60knots at 10,000ft

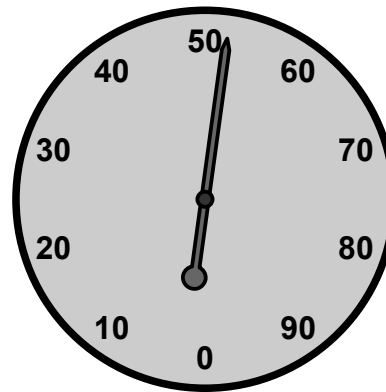

ASI of an aircraft flying at 60knots at 20,000ft

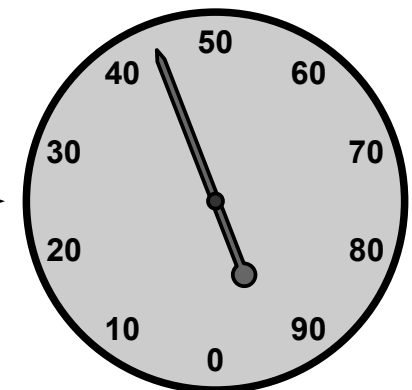

[TAS and IAS]

TAS: True Air Speed

The true speed at which the aircraft is moving through the air.



IAS: Indicated Air Speed

The airspeed displayed on the ASI.
At altitudes above sea level this will be lower than the true airspeed.

What is the point of an ASI that isn't capable of displaying true airspeed at altitudes above sea level?

We will attempt to answer this question over the next couple of slides...

[Flight dynamics, altitude and TAS]

1 The decrease in air density with altitude also affects a glider's flight dynamics.

2 For example, a glider that stalls at a true airspeed of 40knots in steady wings level flight at 1,000ft, will stall at a true airspeed of 54knots at 20,000ft.

3 Consider therefore the inconvenience that this would cause if the ASI did actually display true airspeed (TAS). The pilot would need to continuously use quick reference cards to look up the stall speed, best L/D speed and min sink speed for the current altitude. Not a particularly convenient thing to have to do while trying to fly.

Altitude	True airspeed (TAS) at which stall occurs in steady wings level flight
1,000ft	40 knots
10,000ft	46 knots
20,000ft	54 knots
30,000ft	64 knots
40,000ft	79 knots

Table 1: Illustration⁽⁺⁾ showing how steady wings level flight stall speed is affected by altitude.

⁽⁺⁾ Remember that different gliders stall at different speeds. This table is just an illustration. The figures for your glider will be different, but the trend will be the same.

[Flight dynamics, altitude and IAS]

1 Fortunately for the pilot, the amount by which the ASI under reads approximately cancels out the air density related changes to the glider's flight dynamics.

2 This means that if the indicated airspeed (IAS) at the point of stall at 1,000ft in steady wings level flight is 40knots. Then the indicated airspeed at 20,000ft at the point of the stall will also be 40knots. Despite the fact that the stall is actually occurring at a 14knot higher true airspeed.

3 The pilot therefore only needs to remember one set of numbers that will work at all altitudes.

There is however one very important exception...

Altitude	Indicated airspeed (IAS) at which stall occurs in steady wings level flight
1,000ft	40 knots
10,000ft	40 knots *
20,000ft	40 knots *
30,000ft	40 knots *
40,000ft	40 knots *

Table 2: Illustration⁽⁺⁾ showing that the indicated airspeed (IAS) at which a glider stalls in steady wings level flight does not vary with altitude.

⁽⁺⁾ Remember that different gliders stall at different speeds. This table is just an illustration. The IAS figure for your glider will be different.

* In reality, secondary effects will cause small variations as altitude increases.

[IAS and Vne]

1 The previous slide detailed how most of the flight characteristics of a glider (stall speed, best L/D speed etc.) occur at a particular indicated airspeed (IAS) regardless of altitude. The exception to this rule is Vne.

2 The indicated airspeed (IAS) at which Vne is reached decreases with altitude.

3 A glider's flight manual should therefore include a table such as the one shown on the right, which details how Vne should be reduced with altitude.

Altitude	Vne (IAS)
5,000ft	151 knots
10,000ft	144 knots
15,000ft	132 knots
20,000ft	121 knots

Table 3: Illustration of how the indicated airspeed (IAS) at which Vne is reached decreases with altitude.

WARNING: These figures will vary from glider to glider. Refer to the manual of your own glider for the figures that are relevant to you!

[The variometer]

[Diaphragm variometer anatomy]

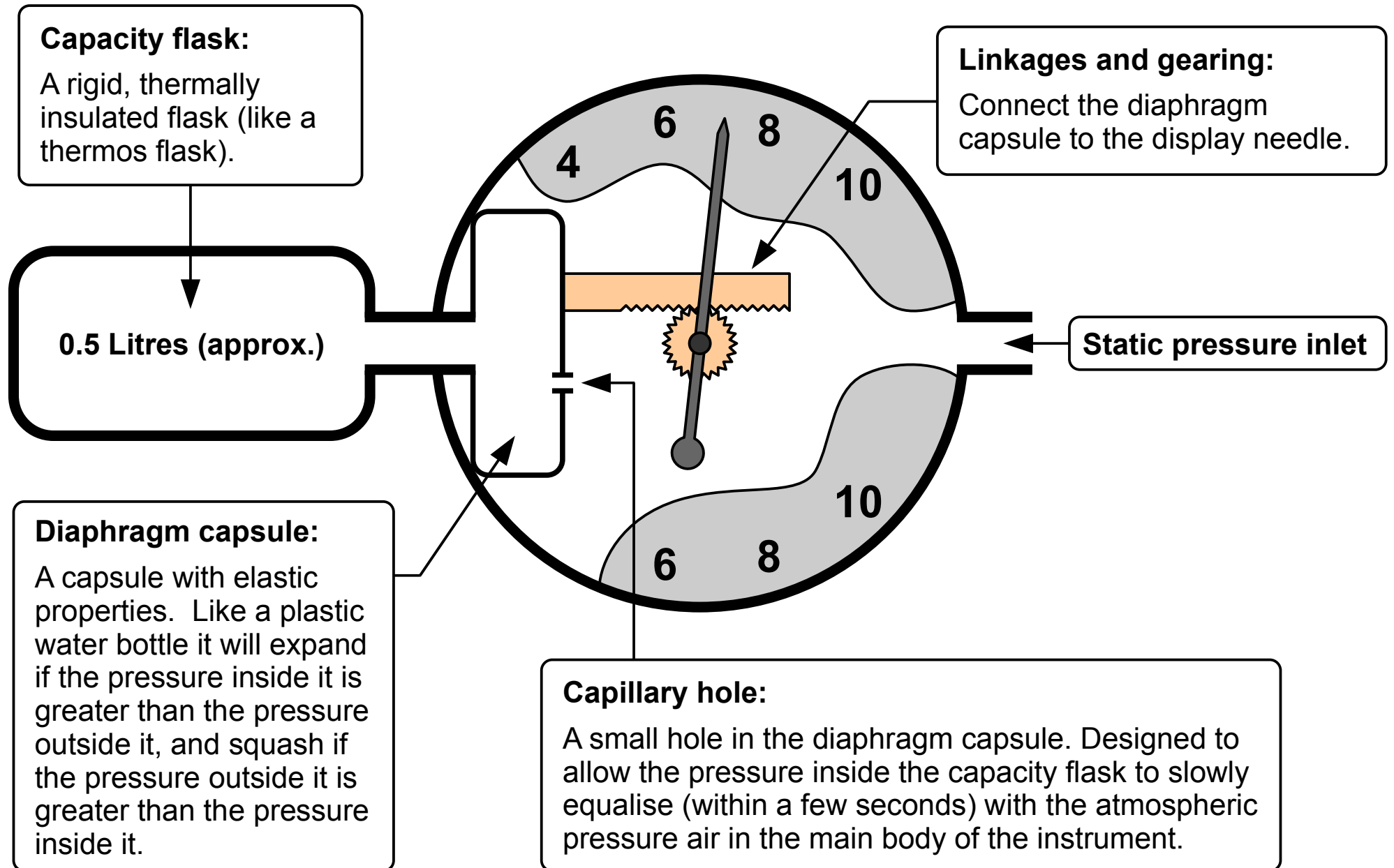

[Variometer pipework : uncompensated]

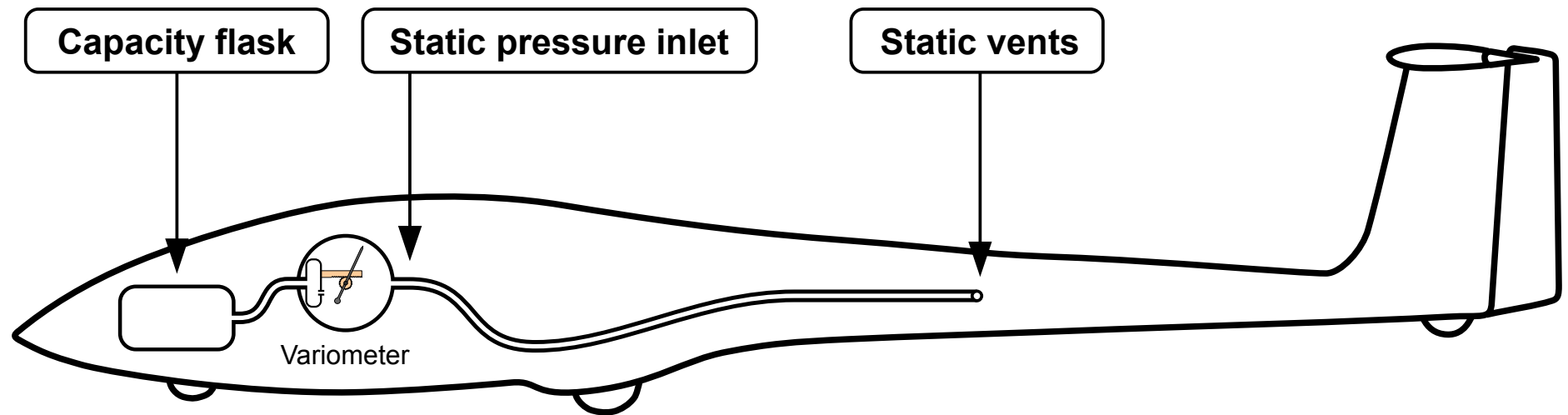

1 A variometer that is connected to the pipework shown above is termed as being **uncompensated**.

2 This style of pipework was used in the early days of gliding and is the pipework used in powered aircraft today.



Because of its relative simplicity we will first discuss the operation of the uncompensated variometer before moving on to the total energy compensated system's used in modern gliders today...

[Uncompensated variometer : level flight]

1 In level flight, the pressures throughout the variometer and capacity flask will equalise to the local atmospheric pressure at the flight altitude via the static vents.

2 Hence there will be no difference between the pressure inside and the pressure outside the diaphragm capsule.

3 The capsule will therefore neither be squashed nor inflated and the display needle will point to zero.

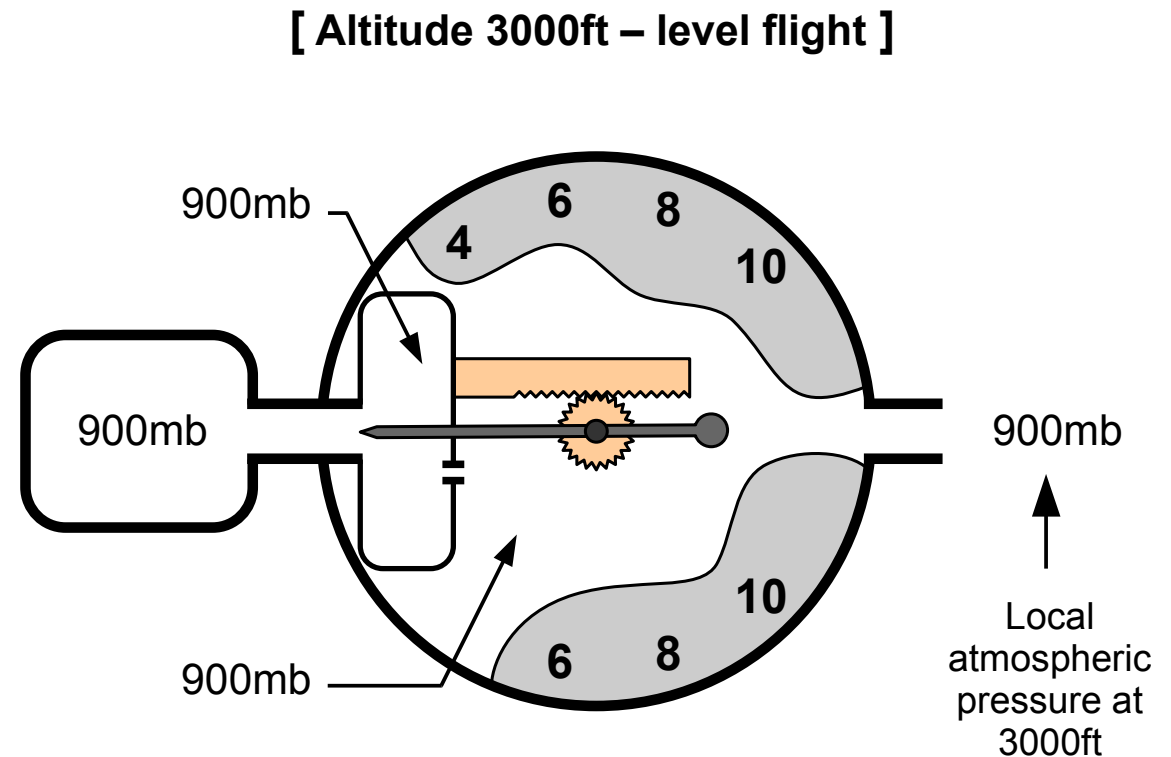

[Uncompensated variometer : height gain]

1 As a glider climbs the atmospheric pressure around the glider will fall.

2 The pressure inside the variometer's case will match this pressure drop almost instantaneously.

3 However the pressure of the air inside the capacity flask will take several seconds to "catch up" because it has to vent through the small capillary hole.

4 Therefore during a climb, the pressure inside the capacity flask and diaphragm capsule will be slightly higher than the pressure inside the variometer's case. The diaphragm capsule will therefore expand, rotating the display needle to show an increasing altitude.

[Altitude 3500ft during climb from 3000ft to 4000ft]

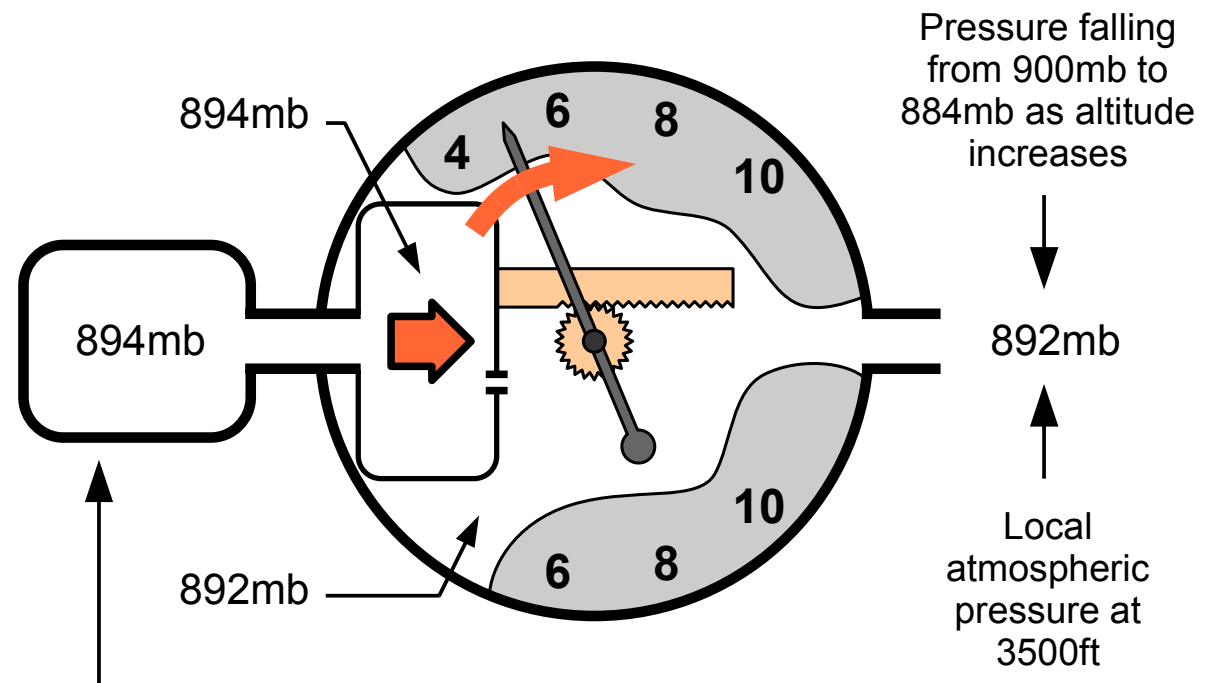

Decrease of pressure in capacity flask lags behind decrease in atmospheric pressure because air has to vent through the small capillary hole.

[Uncompensated vario characteristics]

➡ An uncompensated variometer will display changes in altitude generated by...

1 The natural sink rate of the glider.

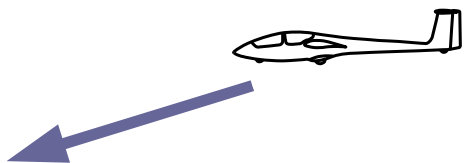

2 External up or down drafts that cause the glider to gain or lose altitude (E.g. thermals).

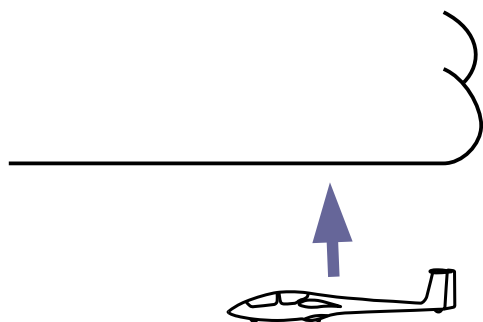

3 Changes in altitude caused by the glider slowing down or speeding up. (E.g. if you pull back on the stick the glider will slow down and gain altitude as speed is converted into height)

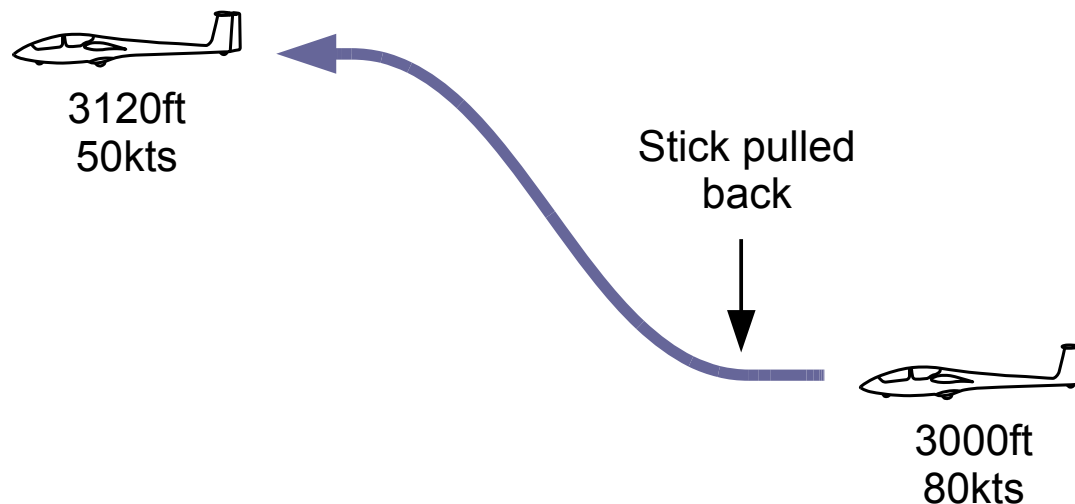

As a glider pilot you don't actually want a variometer to display this type of altitude change, because every time you slow down you will think you are in a strong thermal.

[Variometer pipework : TE compensated]

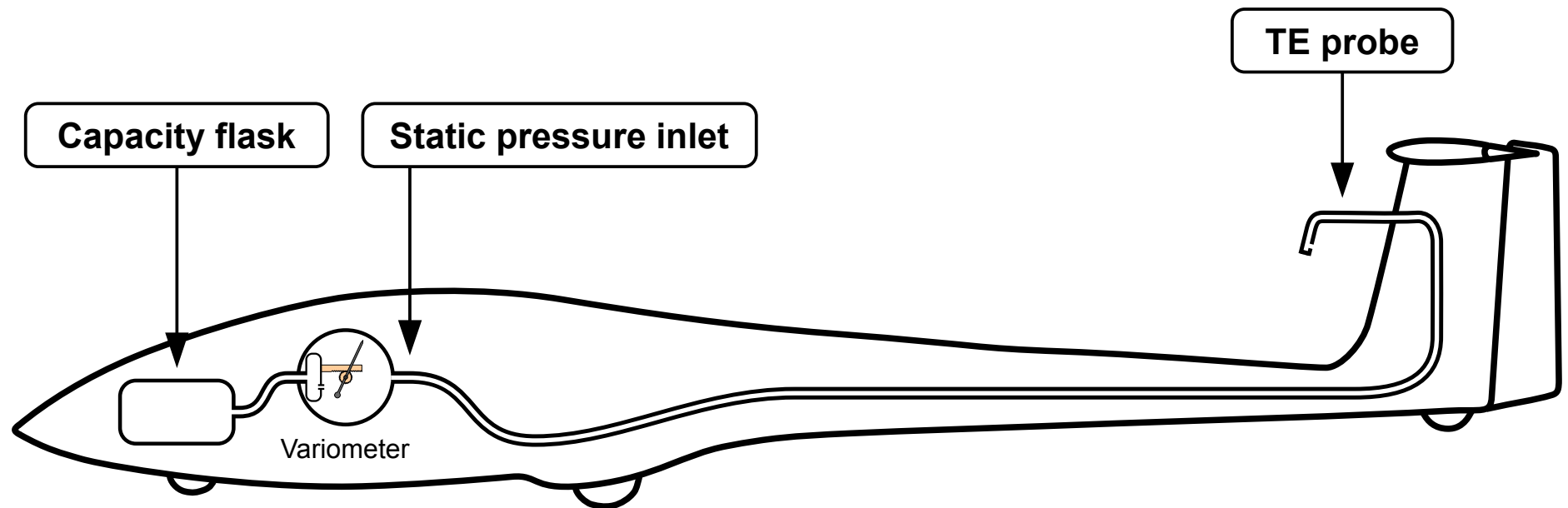

1 A variometer connected to a Total Energy (TE) probe rather than the static vents will not display altitude changes that are caused by changes in the glider's speed.

2 The variometer will still display altitude changes caused by the glider's natural sink rate and external up and down drafts such as thermals.

[“Venturi” style TE probe anatomy]

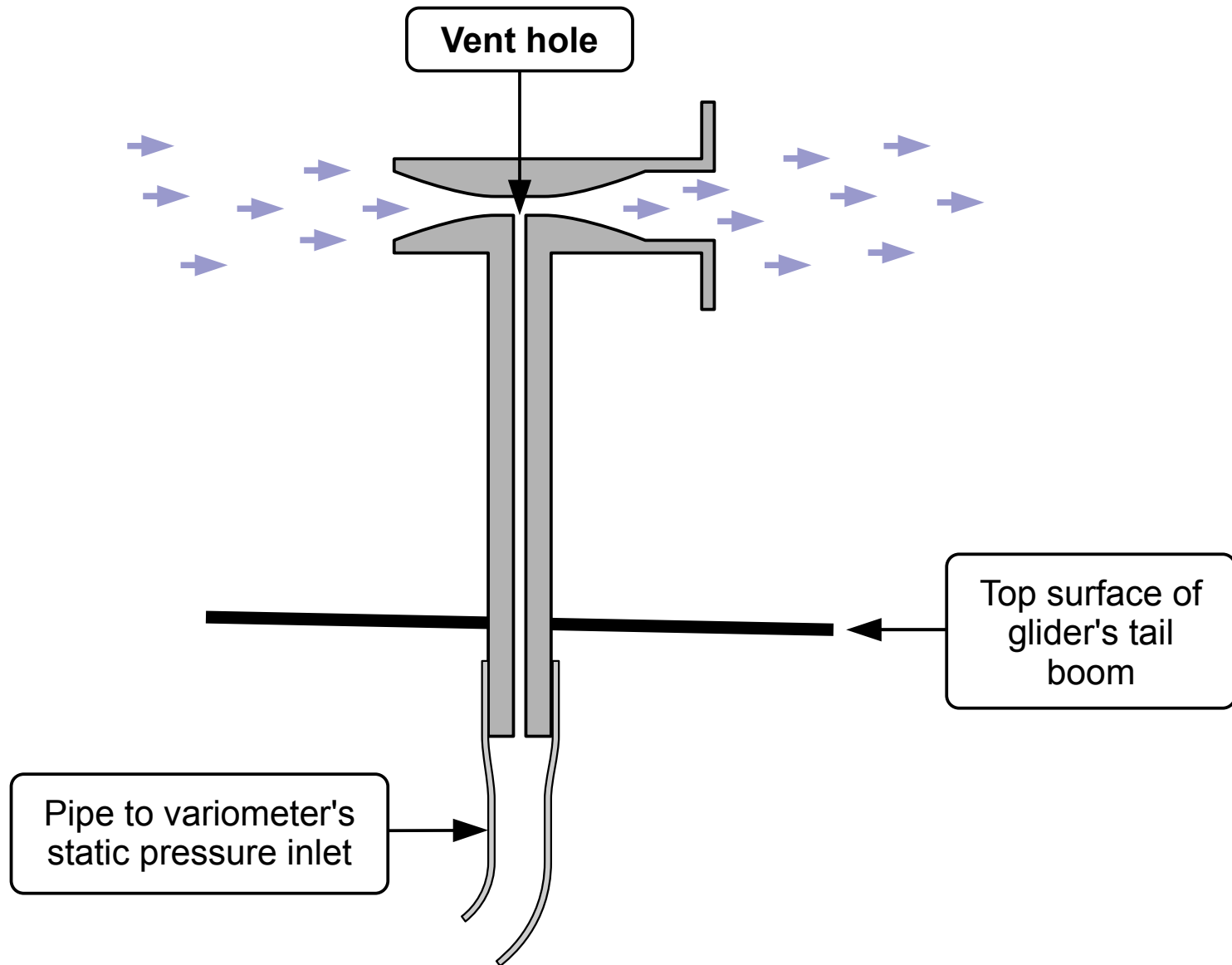

[“Bent pipe” style TE probe anatomy]

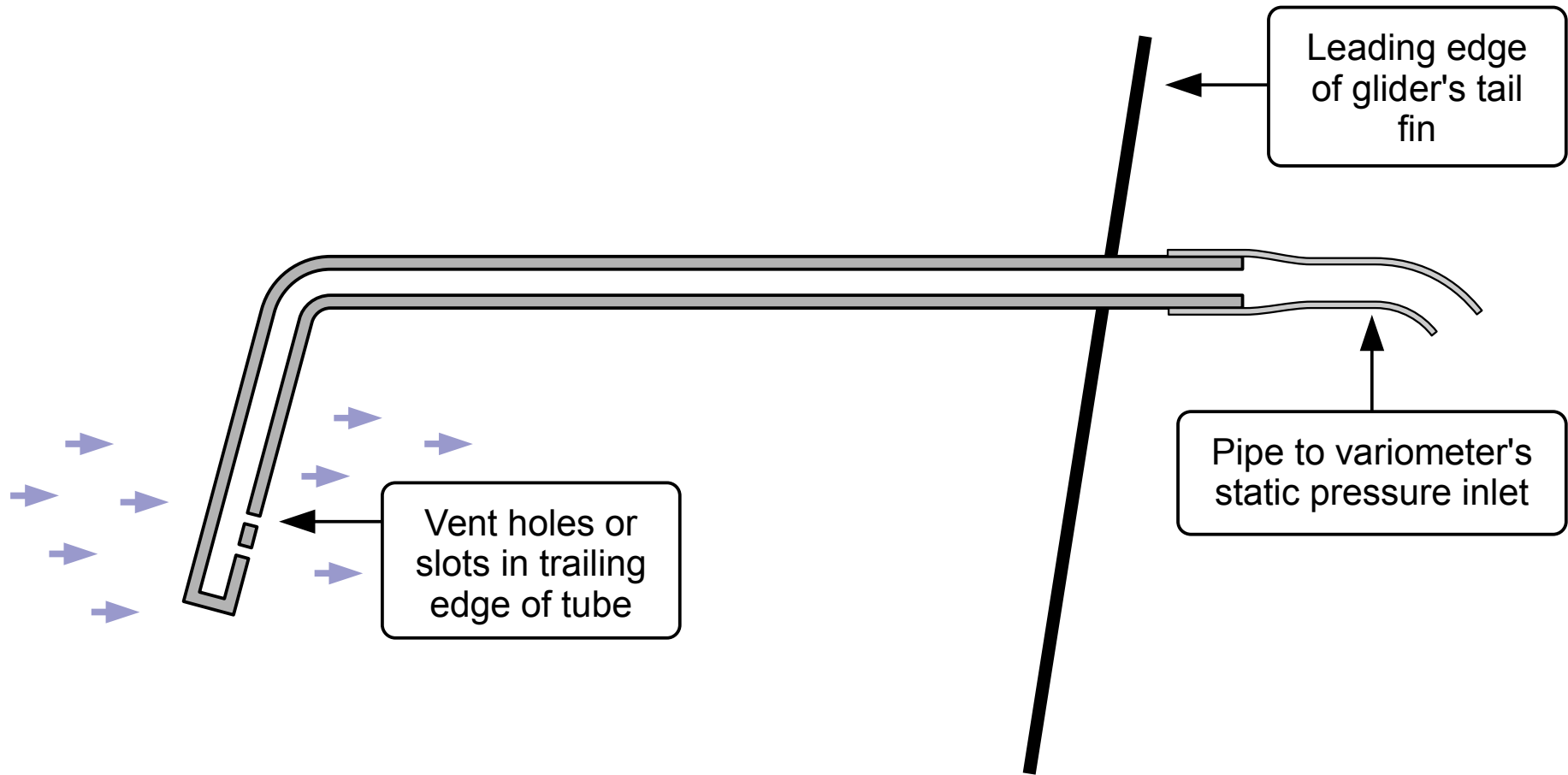

[Airflow around a TE probe]

1 The air flowing through or around a TE probe generates a region of low pressure over the probe's vent hole(s). This is caused by the same physics that generates an area of low pressure over a wing.

2 The faster the aircraft flies the lower the pressure over the vent hole(s) relative to the surrounding air.

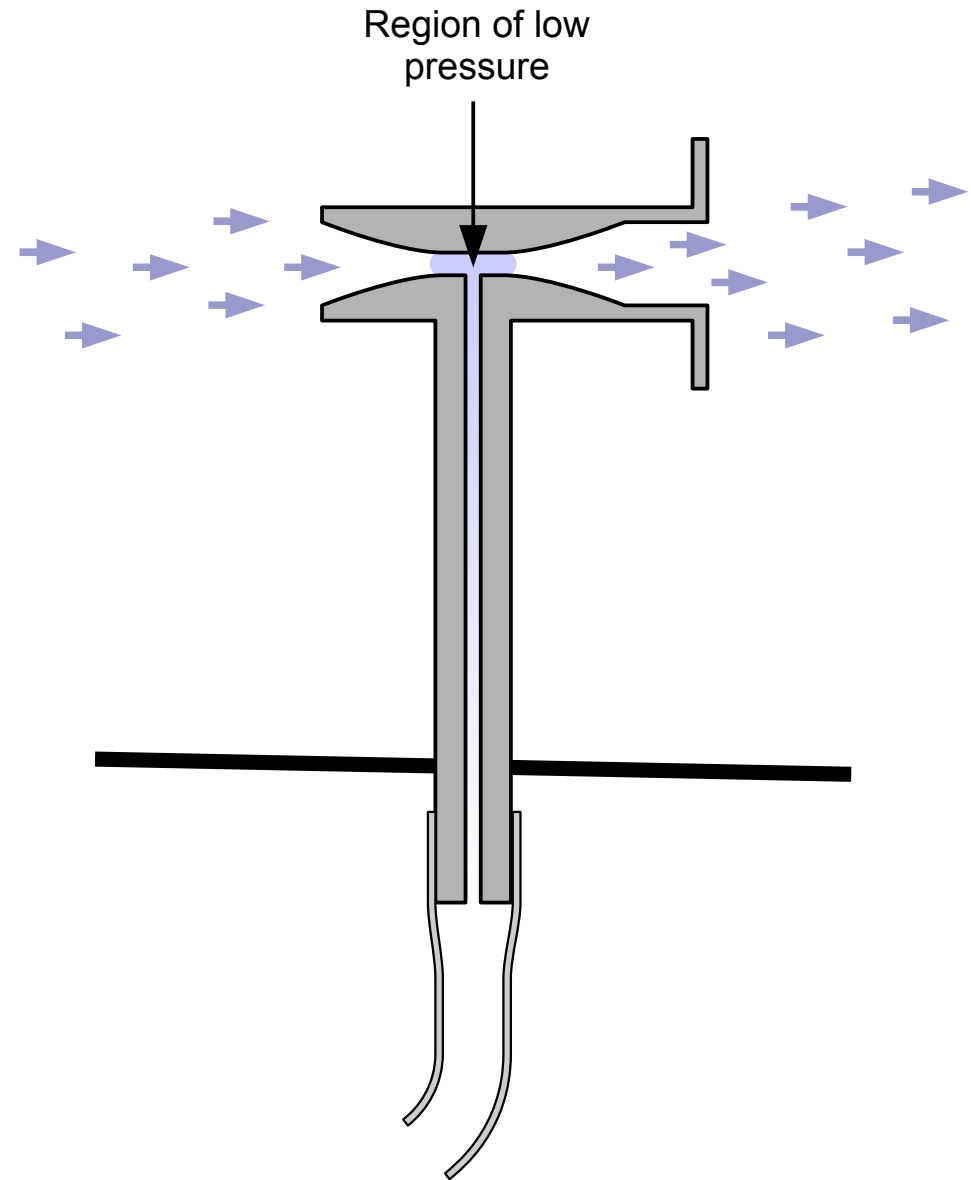

[Advanced topic: How a TE probe works]

1 When a pilot pulls back on the stick, the glider will convert speed to altitude. Hence the atmospheric pressure around the aircraft will decrease.

2 Nominally an uncompensated variometer would display an increased rate of ascent during this manoeuvre.

3 However because the aircraft slows down, the pressure reduction over the TE probe's vent hole(s) decreases. This cancels out the decrease in atmospheric pressure due to the gain of altitude.

4 The TE compensated variometer therefore doesn't register a "stick induced" change of altitude.

[Any questions?]

Document revision: 02 - 13/12/2009

All outlines of ASK-21 gliders contained in this presentation are Copyright 1983 Alexander Schleicher GmbH & Co and are used here with their kind written permission.

All other content is Copyright 2009 Richard Lancaster.

For non-commercial educational purposes permission is granted to project, print as handouts, email and distribute this presentation on physical digital media.

Permission is also granted to distribute this presentation between acquaintances on a non-commercial basis via email, physical digital media and hard copy printouts.

However this presentation may not be otherwise republished or redistributed by any means electronic or conventional without prior written permission of the copyright holders. In particular this presentation may not be used for any commercial purposes whatsoever.

This presentation may not be altered in any way without prior written permission of Richard Lancaster.

The latest revision of the presentation can always be downloaded from:

www.carrotworks.com

Richard Lancaster
R.Lancaster@carrotworks.com